

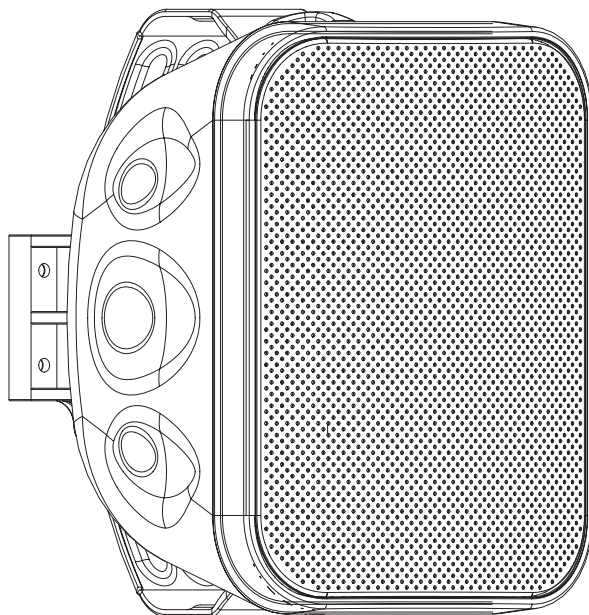

TAGA
HARMONY

TOS Platinum SE / TOS Platinum TOS / TOW Series

OUTDOOR-INDOOR and ON-WALL SPEAKERS



Instruction Manual

Introduction

Thank you for purchasing TAGA Harmony Speakers.

TAGA Harmony speakers are the ideal solution for outdoor (selected models – confirm which with your local dealer) and indoor sound systems.

They provide clean, natural, dynamic and powerful sound performance.

Most models are weather, UV and water resistant.

Mounting brackets (selected models) make installation very easy as well as speakers can be mounted horizontally and vertically.

The SM (stereo / mono) models ensure high quality, dual-channel sound from a single speaker. The SM models can provide much wider dispersion than traditional speakers as well as eliminate sound imbalances which can be heard once listeners move around the area.

This instruction manual provides all of the information that you need to know about your TAGA Harmony speakers. Please read it carefully before you start using the unit.

Cleaning

Do not use strong or abrasive cleaners. Use a dry, soft cloth for cleaning.

Specifications

Full technical specifications are available on the www.TagaHarmony.com website.

Contents

Speaker Placement	4
Hooking Up the Wires	7
Speaker Mounting	8
Additional Info	10
Notes	11

Speaker Placement

Please spend some time considering placement prior to installing the speaker. Once it is installed, it is not to be easily moved or repositioned. Each room has its specific acoustics but there are some general rules:

LOCATION

TAGA Harmony speakers can be installed almost anywhere thanks to our unique sound characteristic which is strong and powerful, and has a wide dispersion field.

All TOS speakers are equipped with regulated U mounting brackets. Some TOS models have an option to use other mounting brackets, which are not included with the speakers (check this option with your local dealer).

GENERAL NOTES

On-wall	On-ceiling (not applicable for TOW Series)
Placing the speakers near a corner will tend to increase their bass output, but may result in “boomy” or “muddy” sound.	Corner placement close to the walls provides a good balance of bass output and accuracy.
Placing the speakers further into the room will tend to decrease their bass output, but may result in improved articulation and clarity.	
Place the speakers at least 60 cm (2 feet) away from corners and other surfaces which may interfere or reflect sound (like tall furniture).	
To add extra bass and definition to your system we recommend TAGA Harmony Custom Installations or traditional subwoofers.	

All speakers except Stereo/Mono Placement for critical listening in stereo (2 speakers)

On-wall	On-ceiling (not applicable for TOW Series)
Place the front left and right speakers at an equal distance from your listening position, at ear level while seated.	Place the left and right speakers at an equal distance from your listening position. Aim the speaker toward your listening position (if your speakers have this feature).
If the speakers are installed on a wall which is around 300 cm (10 feet) away from your listening position, place them no more than 300 cm (10 feet) apart from each other and no less than 150 cm (5 feet).	Place the speakers no more than 300 cm (10 feet) apart from each other and no less than 150 cm (5 feet).

Placement for entertainment listening or background music (1 or more speakers)

On-wall	On-ceiling (not applicable for TOW Series)
In rectangular smaller rooms [below 30 square meters (320 square feet)] usually 1 or 2 speakers should work fine. If you use 2 – place them near opposite corners. If you use 1 – place it on the most empty and biggest wall.	In rectangular smaller rooms [below 30 square meters (320 square feet)] usually 1 or 2 speakers should work fine. If you use 2 – place them near opposite corners. If you use 1 – place it in the center .
In irregular or larger rooms use more than 2 speakers and place them evenly across the space for good sound dispersion.	

Speaker Placement

Placement for Home Theatre

(the pictures shown for the listening position in the middle of the room)

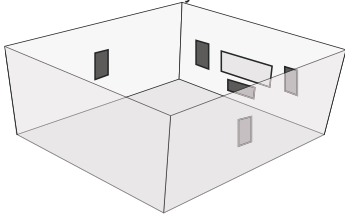
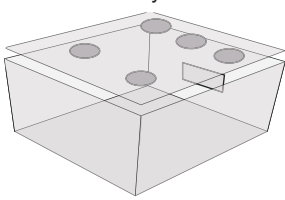
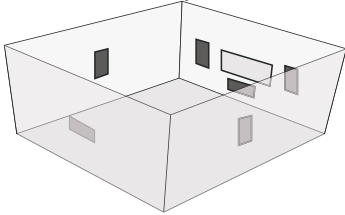
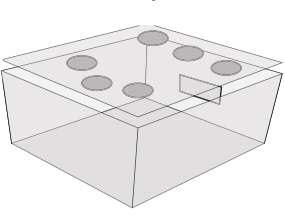
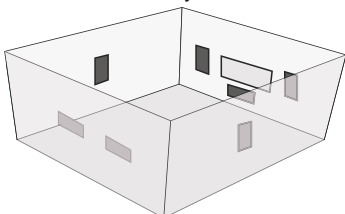
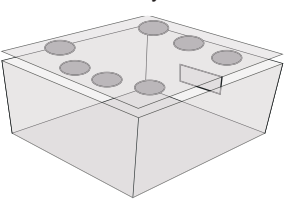
On-wall	On-ceiling
<p data-bbox="260 248 415 272">5.0/5.1 Systems</p>  <p>A 3D perspective diagram of a room showing speaker placement for a 5.0/5.1 system. The front wall has a center channel speaker (white rectangle) and two side channel speakers (grey rectangles). The left and right side walls each have a surround speaker (black rectangle). The rear wall has a subwoofer (grey rectangle).</p>	<p data-bbox="721 248 875 272">5.0/5.1 Systems</p>  <p>A 3D perspective diagram of a room showing speaker placement for a 5.0/5.1 system on the ceiling. The front wall has a center channel speaker (white rectangle) and two side channel speakers (grey rectangles). The left and right side walls each have a surround speaker (black rectangle). The rear wall has a subwoofer (grey rectangle).</p>
<p data-bbox="260 504 415 528">6.0/6.1 Systems</p>  <p>A 3D perspective diagram of a room showing speaker placement for a 6.0/6.1 system. The front wall has a center channel speaker (white rectangle) and two side channel speakers (grey rectangles). The left and right side walls each have a surround speaker (black rectangle). The rear wall has a subwoofer (grey rectangle) and a rear surround speaker (black rectangle).</p>	<p data-bbox="721 504 875 528">6.0/6.1 Systems</p>  <p>A 3D perspective diagram of a room showing speaker placement for a 6.0/6.1 system on the ceiling. The front wall has a center channel speaker (white rectangle) and two side channel speakers (grey rectangles). The left and right side walls each have a surround speaker (black rectangle). The rear wall has a subwoofer (grey rectangle) and a rear surround speaker (black rectangle).</p>
<p data-bbox="260 764 415 788">7.0/7.1 Systems</p>  <p>A 3D perspective diagram of a room showing speaker placement for a 7.0/7.1 system. The front wall has a center channel speaker (white rectangle) and two side channel speakers (grey rectangles). The left and right side walls each have a surround speaker (black rectangle). The rear wall has a subwoofer (grey rectangle), a rear surround speaker (black rectangle), and two additional rear surround speakers (grey rectangles).</p>	<p data-bbox="721 764 875 788">7.0/7.1 Systems</p>  <p>A 3D perspective diagram of a room showing speaker placement for a 7.0/7.1 system on the ceiling. The front wall has a center channel speaker (white rectangle) and two side channel speakers (grey rectangles). The left and right side walls each have a surround speaker (black rectangle). The rear wall has a subwoofer (grey rectangle), a rear surround speaker (black rectangle), and two additional rear surround speakers (grey rectangles).</p>

Speaker Placement

On-wall	On-ceiling (not applicable for TOW Series)
FRONT SPEAKERS	
<p>Place the left and right speakers at an equal distance from your listening position, slightly above ear level while seated.</p> <p>If the speakers are installed on a wall which is around 300 cm (10 feet) away from your listening position, place them no more than 300 cm (10 feet) apart from each other and no less than 150 cm (5 feet).</p>	<p>Place the left and right speakers at an equal distance from your listening position, in front of your TV and about 60 – 90 cm (2 – 3 feet) away from the wall.</p> <p>If the speakers are installed around 300 cm (10 feet) away from your listening position, place them no more than 300 cm (10 feet) apart from each other and no less than 150 cm (5 feet).</p>
CENTER SPEAKER	
<p>Place the speaker at ear level while seated. If you have a TV mounted on wall, place the speaker slightly below it. If you have a TV on a table, place the speaker above it and angle the speaker down towards ear level while seated (if your speaker is equipped with the U bracket).</p> <p>6.0/6.1 systems – place the second center speaker (rear center) on the opposite wall to the first one – at the same height and angle the speaker down towards ear level while seated (if your speaker is equipped with the U bracket).</p>	<p>Place the speaker horizontally in the middle of the front left and right speakers. Aim the speaker towards the listening position (if your speaker is equipped with the U bracket).</p> <p>6.0/6.1 systems – place the second center speaker (rear center) behind your listening position, in line with the front center speaker . Aim the speaker towards the listening position (if your speaker is equipped with the U bracket).</p>
SURROUND SPEAKERS	
<p>Place the speakers above ear level while seated, but no higher than ear level while standing.</p> <p>5.0/5.1/6.0/6.1 systems – place the right and left surround on the right and left side of your listening position.</p> <p>7.0/7.1 systems – place the right and left surround on the right and left side of your listening position. The two additional rear surround speakers should be placed behind your listening position. They should be placed at equal distances from your listening position, and about half as far as the right and left surrounds. All four surrounds should be mounted at the same height.</p>	<p>5.0/5.1/6.0/6.1/7.0/7.1 systems – place the right and left surround on the right and left side of your listening position, as far apart as your front left and right speakers.</p> <p>7.0/7.1 systems – place the rear right and left surrounds behind your listening position, at equal distances from your position. They should be about half as far apart as the right and left surround speakers positioned on the sides.</p>
<p>We recommend to use TAGA Harmony in-wall/in-ceiling or traditional subwoofer in all Home Theatre systems.</p>	

Speaker Placement

Placement for Stereo/Mono models

TAGA Harmony Stereo/Mono models offer wider sound dispersion than regular speakers.

STEREO CONNECTION	MONO CONNECTION
SINGLE SPEAKER	
In smaller areas where a stereo pair of speakers cannot be used or where a single speaker is preferred to be used. 7.0/7.1 systems – use the speaker as rear center speaker. Position tweeters towards the left and right sides of the room.	6.0/6.1 systems – use the speaker as rear center speaker. Position tweeters towards the left and right sides of the room.
MULTIPLE SPEAKERS	
In larger areas to eliminate the sound imbalances and offer better sound coverage. 7.0/7.1 systems – use two speakers as surround speakers. Position one tweeter of each speaker towards the front side of the room and the other tweeter towards the back side.	5.0/5.1 systems – use two speakers as surround speakers. Position one tweeter of each speaker towards the front side of the room and the other tweeter towards the back side.

Hooking Up the Wires

The speaker terminal can accommodate up to 10 AWG speaker cables (selected models only - others up to 14 AWG). 10 or 14 AWG speaker cables are recommended for longer connections (greater than 20 meters / 66 feet)). For shorter lengths you can use 16 or 18 AWG speaker cables. It is recommended to leave about 150 cm (5 feet) of extra cable at the speaker end to facilitate positioning and installation of the speaker. Do not use staples, nails or other metal objects to secure the speaker cables. You will get the best sound quality and least amount of hum by keeping the speaker cables away from other electrical wires and cables.

Pay attention to connecting the polarity of the speaker correctly with the amplifier speakers output terminals (RED + with RED +, BLACK - with BLACK -). Before connecting the speaker make sure that your amplifier is switched off. Please refer to your amplifier's instruction manual for more information.

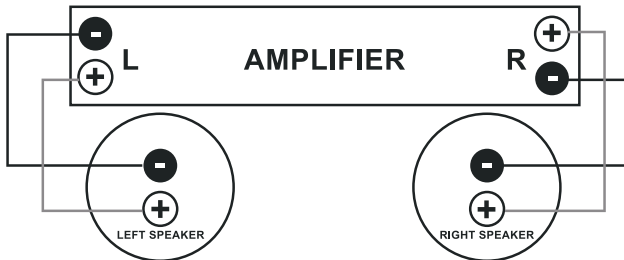

WARNING! Check whether your amplifier may work with impedance of your TAGA Harmony speaker. Otherwise you may burn the amplifier and damage the speakers - it may void your warranty.

Hooking Up the Wires

Stereo/Mono Models

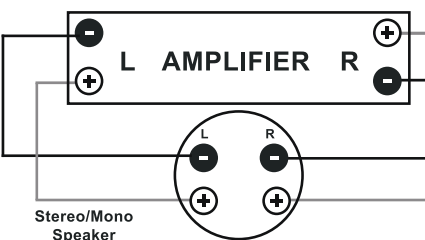
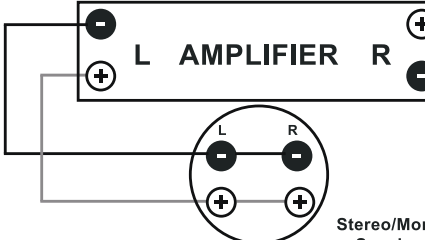
STEREO CONNECTION	MONO CONNECTION
<p>Connect a single speaker to two amplifier speakers output terminals.</p> <p>Connect one amplifier speakers output terminal with one speaker input terminal (RED + with RED +, BLACK – with BLACK -), connect the other amplifier speakers output terminal with the other speaker input terminal (RED + with RED +, BLACK – with BLACK -).</p> 	<p>Connect a single speaker to a single amplifier speakers output terminal.</p> <p>Connect one amplifier speakers output terminal with one speaker input terminal (RED + with RED +, BLACK – with BLACK -). Using a short piece of speaker cable connect Left + (RED) speaker input terminal with Right + (RED) speaker terminal. Do the same for - terminals (BLACK).</p> 

Speaker Mounting

Run the speaker cable to location where the speaker is to be installed. Leave about 20 cm (0.66 feet) of extra cable (if the speaker cable is hidden in a wall or ceiling make a hole in the center of the location of the speaker).

• TOS using U mounting bracket with horizontal regulation:

- Run the speaker cable through an installation hole in the middle of the U bracket.
- Position the bracket on the wall or ceiling where you want to mount the speaker, and mark places of mounting the screws.
- Screw the U mounting bracket onto the wall or ceiling where you want to mount the speaker.

WARNING! Depending on the mounting surface use appropriate screws or wall anchors (ask your local dealer or installer for advice).

- Connect the speaker cable to the speaker terminals.
- Slide the speaker into the U bracket and screw top and bottom bracket knobs to the speaker to secure the speaker in the bracket.
- Adjust the horizontal position of the speaker and fasten (screw in firmly) the knobs. In the future the knobs can be loosen to adjust the speaker horizontal position.

Mounting the Bracket

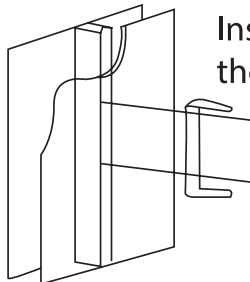

Instaling the Speaker

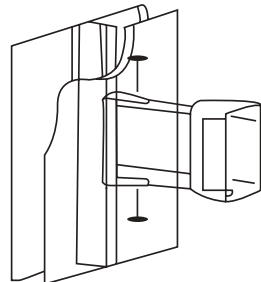

Speaker Mounting

TOS using U mounting bracket with horizontal and vertical regulation:

- Using 4 screws install the wall mount (A) on the wall or ceiling where you want to mount the speaker (Fig. 1).

WARNING! Depending on the mounting surface use appropriate screws or wall anchors (ask your local dealer or installer for advice).

- Attach the U bracket (C) to the wall mount (A), slide in the locking cover (B) and secure it with 4 screws (Fig. 2).

- Remove the speaker terminal box cover, connect the speaker cable to the speaker terminals and firmly place the cover back. (Fig. 3)

- Slide the speaker into the U bracket and screw top and bottom bracket knobs to the speaker to secure the speaker in the bracket. (Fig. 4)

- Adjust the horizontal position of the speaker and fasten (screw in firmly) the knobs. In the future the knobs can be loosen to adjust the speaker horizontal position (Fig. 5).

- Adjust the vertical position of the speaker and secure the chosen position by installing 2 screws on the side of the wall mount (A). In the future the side screws can be removed to adjust the speaker vertical position (Fig. 5).

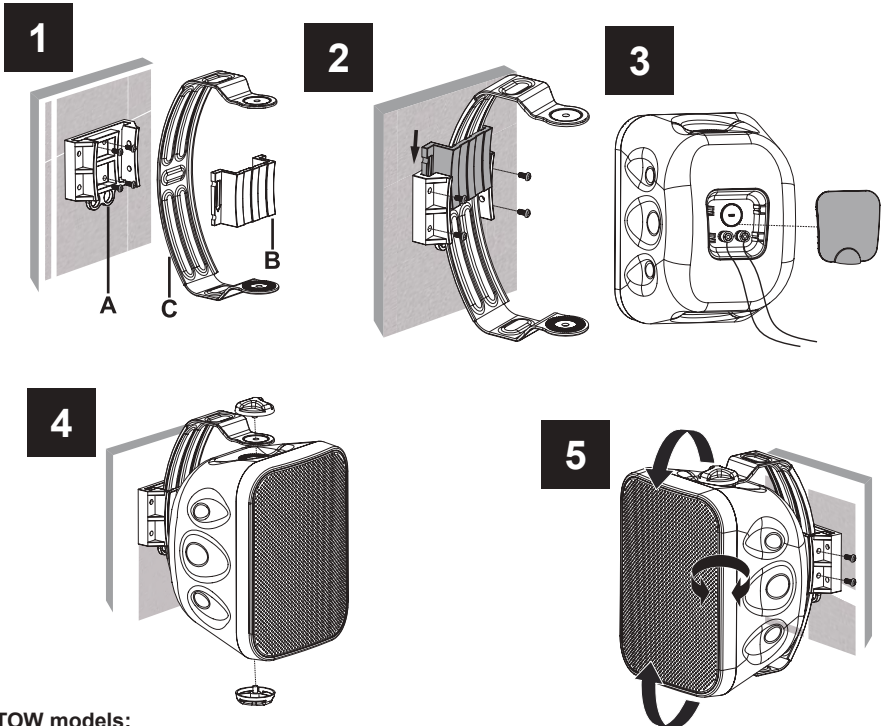

• TOW models:

- Screw a hook in the wall where you want to mount the speaker.

WARNING!

Depending on the mounting surface use appropriate screws or wall anchors (ask your local dealer or installer for advice).

- Connect the speaker cable to the speaker terminals.

- Hang the speaker on the hook.

Note! Screws, hooks and wall anchors may not be included with your speakers.

Additional Info (not applicable for all models)

- **Outdoor Use** - most TOS speakers are weather, UV and water resistant and are designed for use outdoors (selected models – confirm which with your local dealer).
- **U Brackets** – All TOS speakers are equipped with U mounting brackets which allow horizontal regulation and selected models additionally have vertical regulation (confirm which with your local dealer).

We strongly advise to contact a professional installer or dealer in order to install TAGA Harmony products.

We recommend using high quality TAGA Harmony cables and other installation accessories.



Your product is marked with the symbol as showed on the left.
For EU (European Union) member users:
This product has been tested and found in compliance with requirements of the European Community 2014/30/EU (EMC) directive.



IMPORTANT!

Your product is marked with the symbol as showed on the left.
For EU (European Union) member users:

According to the WEEE (Waste electrical and electronic equipment) Directive, do not dispose of this product as household waste or commercial waste. Waste electrical and electronic equipment should be appropriately collected and recycled as required by practices established for your country.
For information on recycling of this product, please contact your local authorities, your household waste disposal service or the shop where you purchased the product.

TAGA EUROPE

POLPAK POLAND Sp. z o.o.
AL.JERZOLIMSKIE 331A
05-816 REGULY k/WARSZAWY, POLAND
Email: Sales@TagaHarmony.com

www.TagaHarmony.com

Notes

Notes
